

P4

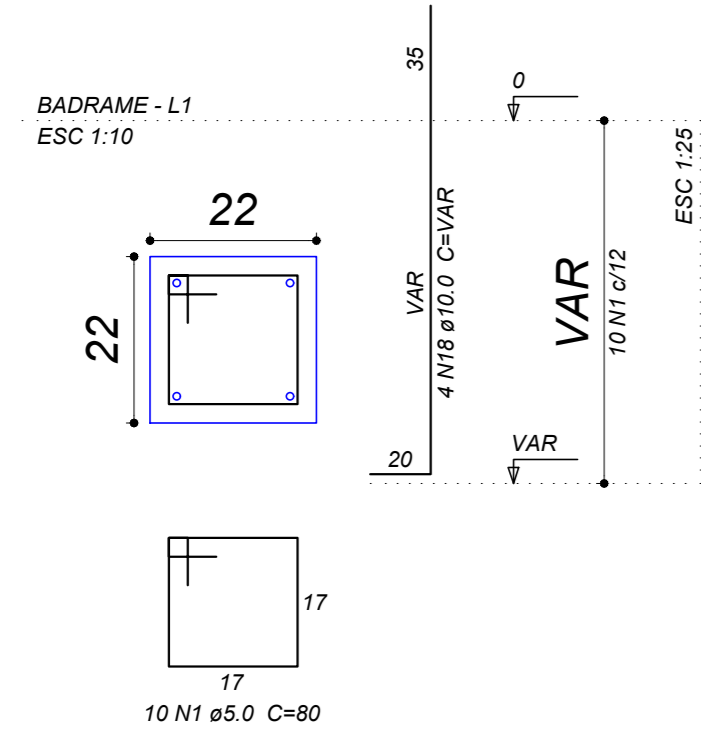

S4
PLANTA
ESC 1:25

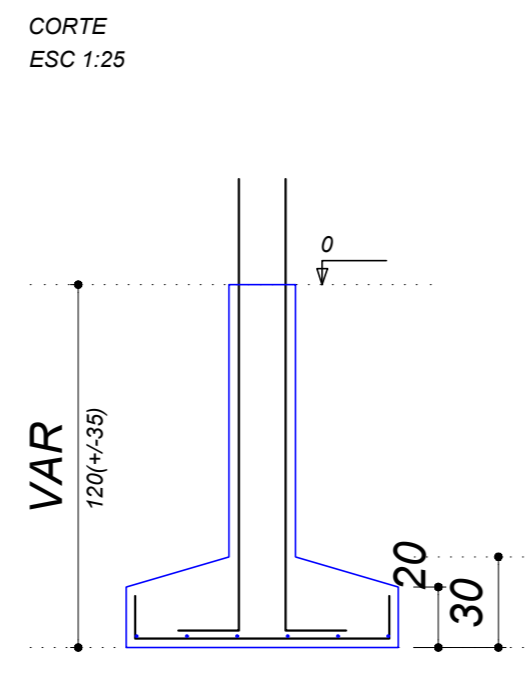
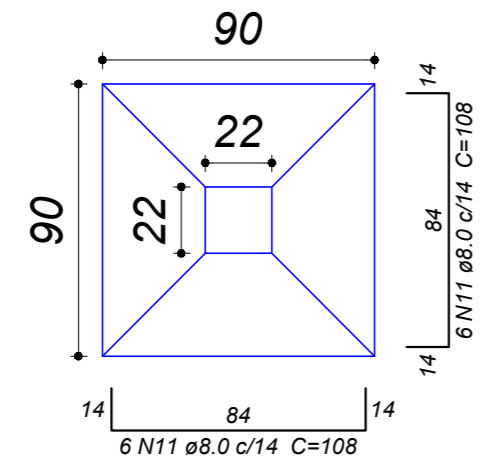

P19=P20=P24=P33=P39

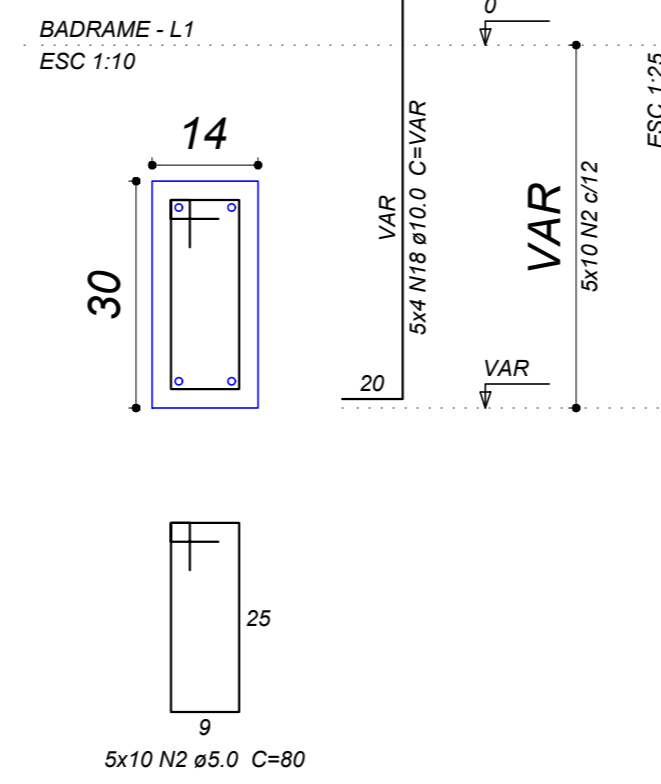

P25=P34

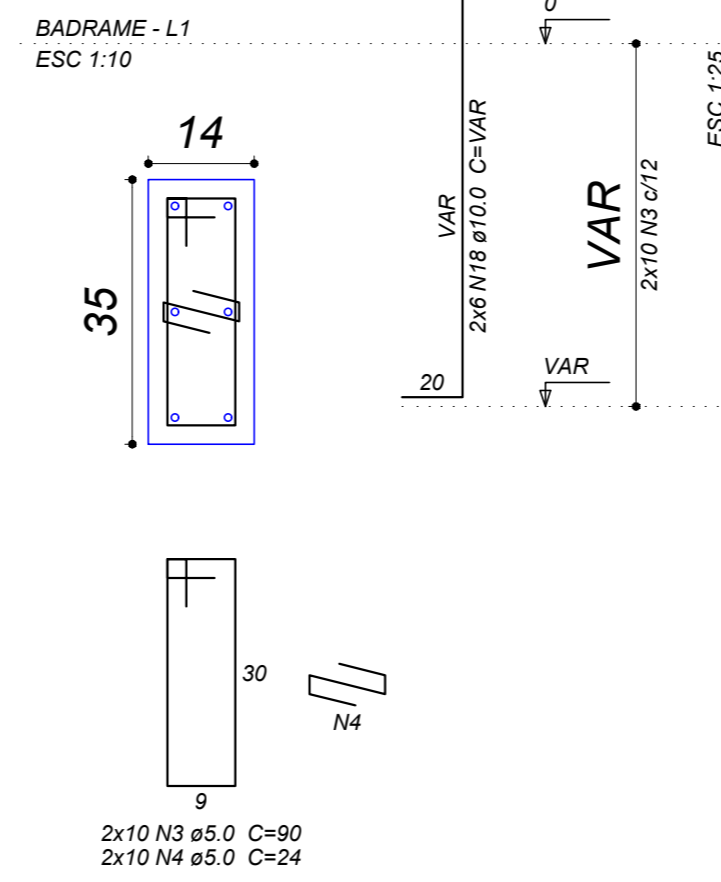

S19=S20=S24=S25=S33=S34=S39
PLANTA
ESC 1:25

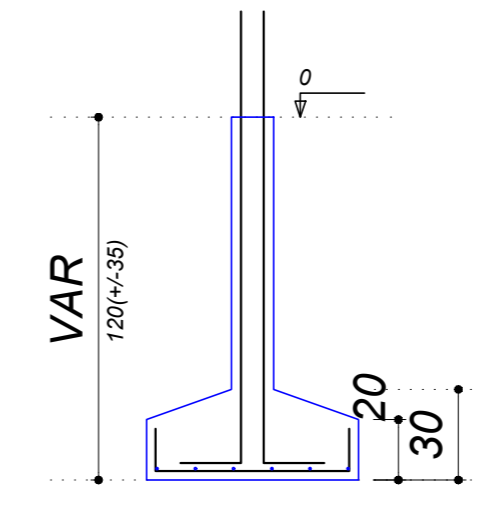
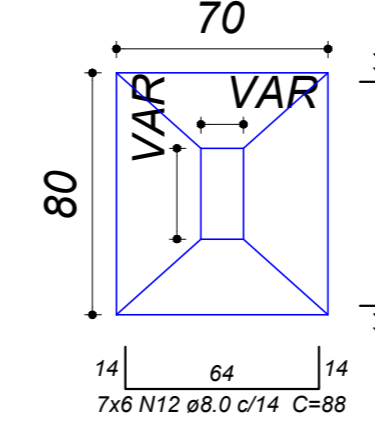

Relação do aço

AÇO	N	DIAM (mm)	QUANT (Barras)	UNIT (cm)	C.TOTAL (cm)
CA60	1	5.0	10	80	800
	2	5.0	70	80	5600
	3	5.0	20	90	1800
	4	5.0	30	24	720
	5	5.0	20	132	2640
	6	5.0	20	50	1000
	7	5.0	40	40	1600
	8	5.0	10	126	1260
	9	5.0	10	37	370
	10	5.0	10	98	980
CA50	11	8.0	22	108	2376
	12	8.0	42	88	3696
	13	8.0	65	98	6370
	14	8.0	12	78	936
	15	8.0	32	168	5376
	16	8.0	6	128	768
	17	8.0	9	138	1242
	18	10.0	64	VAR	VAR
	19	10.0	10	VAR	VAR
	20	10.0	28	147	4116
	21	10.0	2	VAR	VAR
	22	10.0	4	VAR	VAR

Resumo do aço

AÇO	DIAM (mm)	C.TOTAL (m)	QUANT + 10% (Barras)	PESO + 10% (kg)
CA50	8.0	207.7	20	90.1
CA60	5.0	178.3	17	120.9
PESO TOTAL (kg)				211
CA50				211
CA60				28.4

Volume de concreto (C-25) = 4.07 m³
Área de forma = 27.16 m²

P28

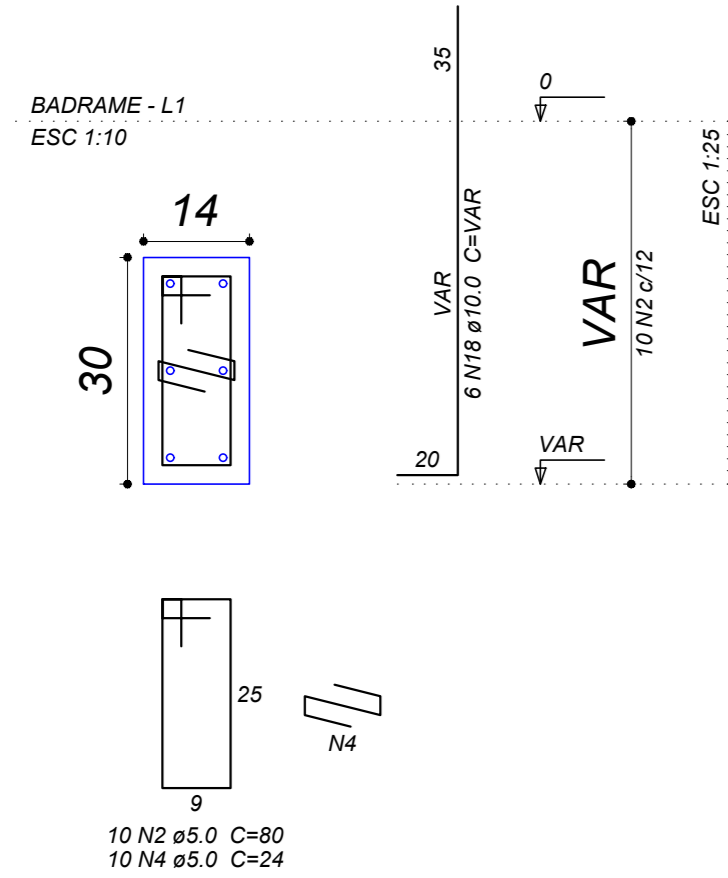

P29

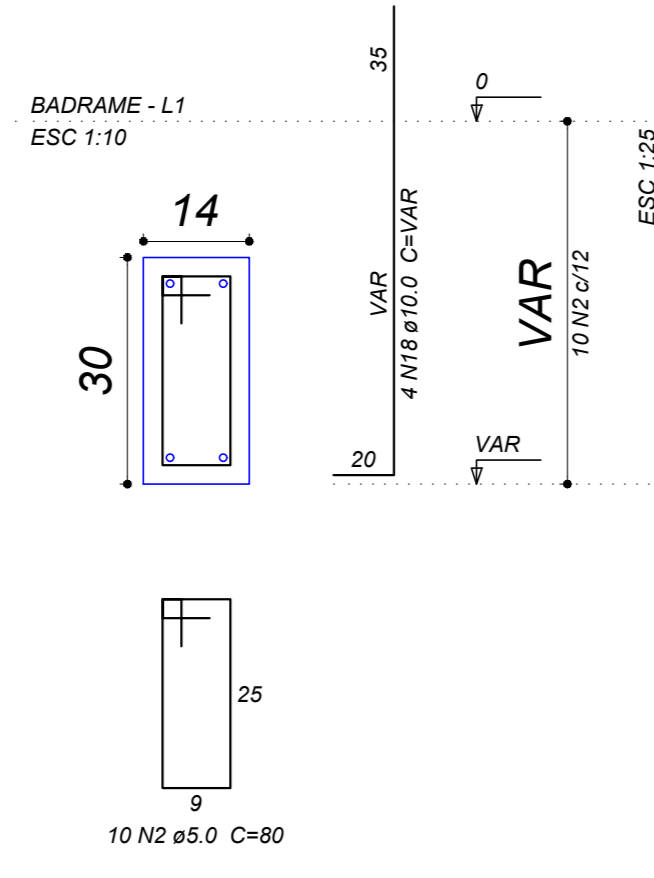

S28=S29
PLANTA
ESC 1:25

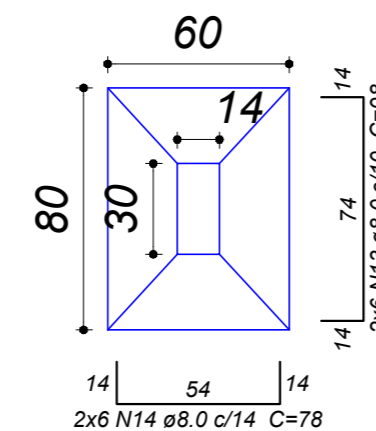

CORTE
ESC 1:25

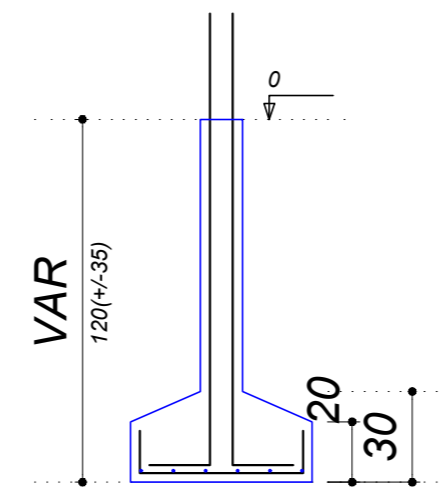

P49

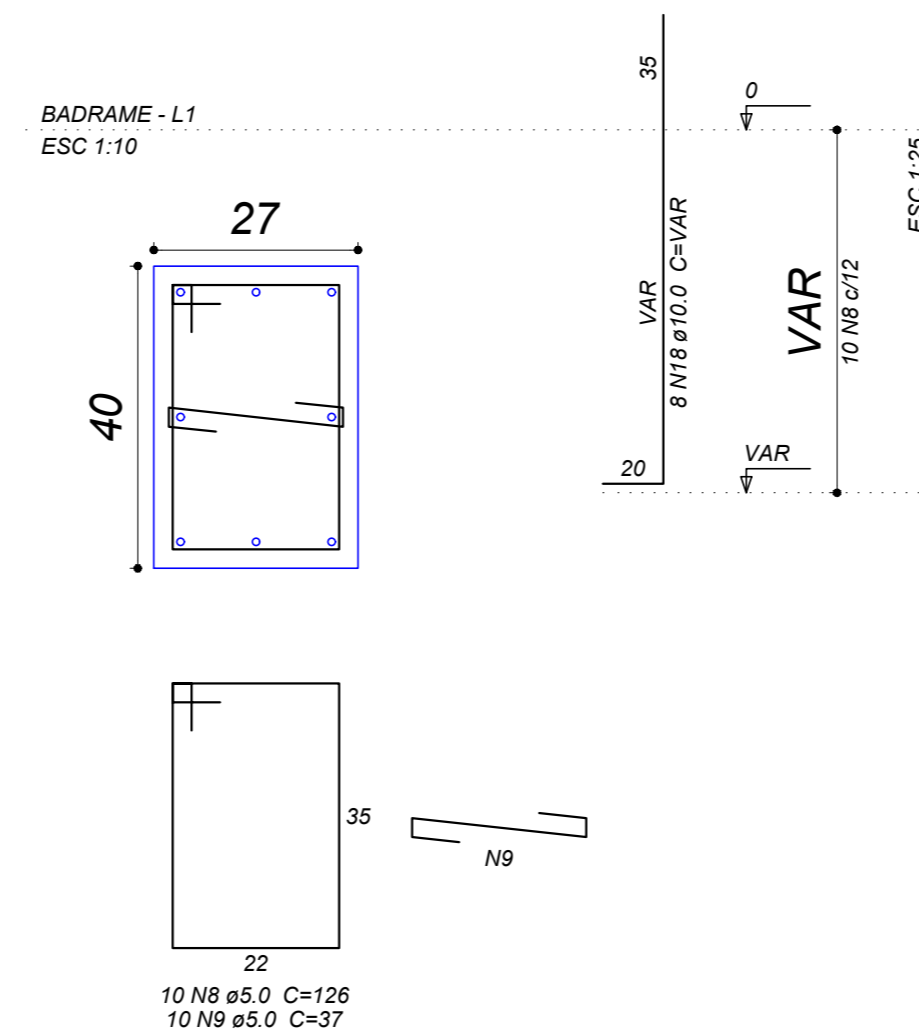

S49
PLANTA
ESC 1:25

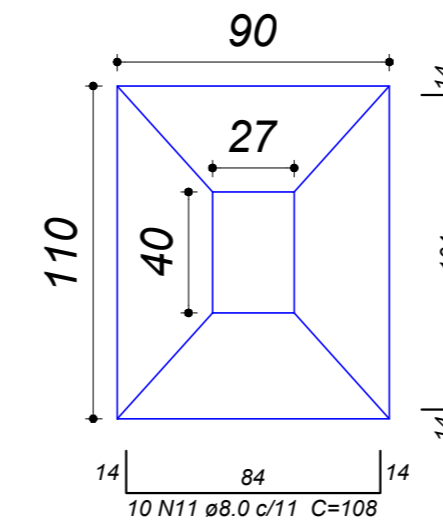

CORTE
ESC 1:25

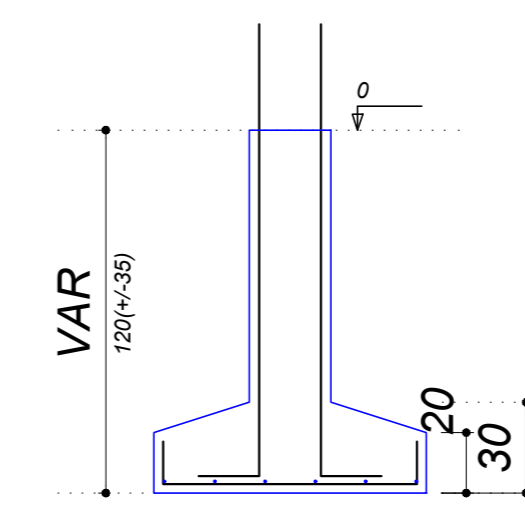

P40

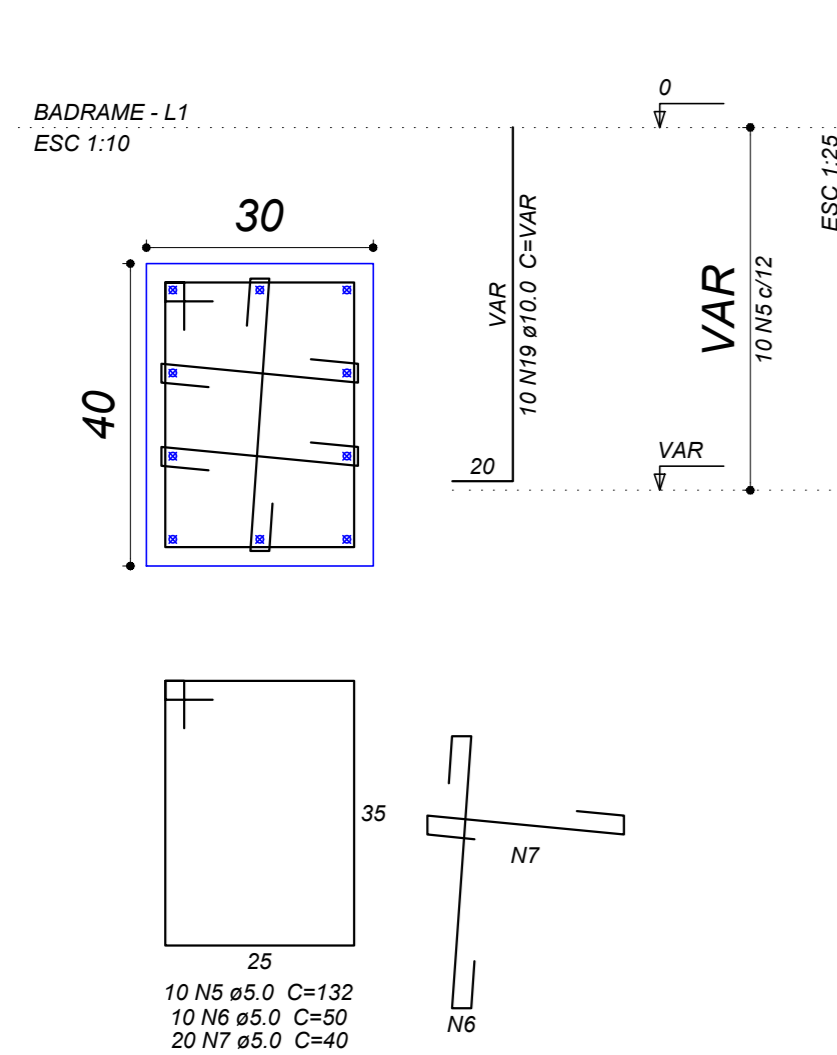

P51

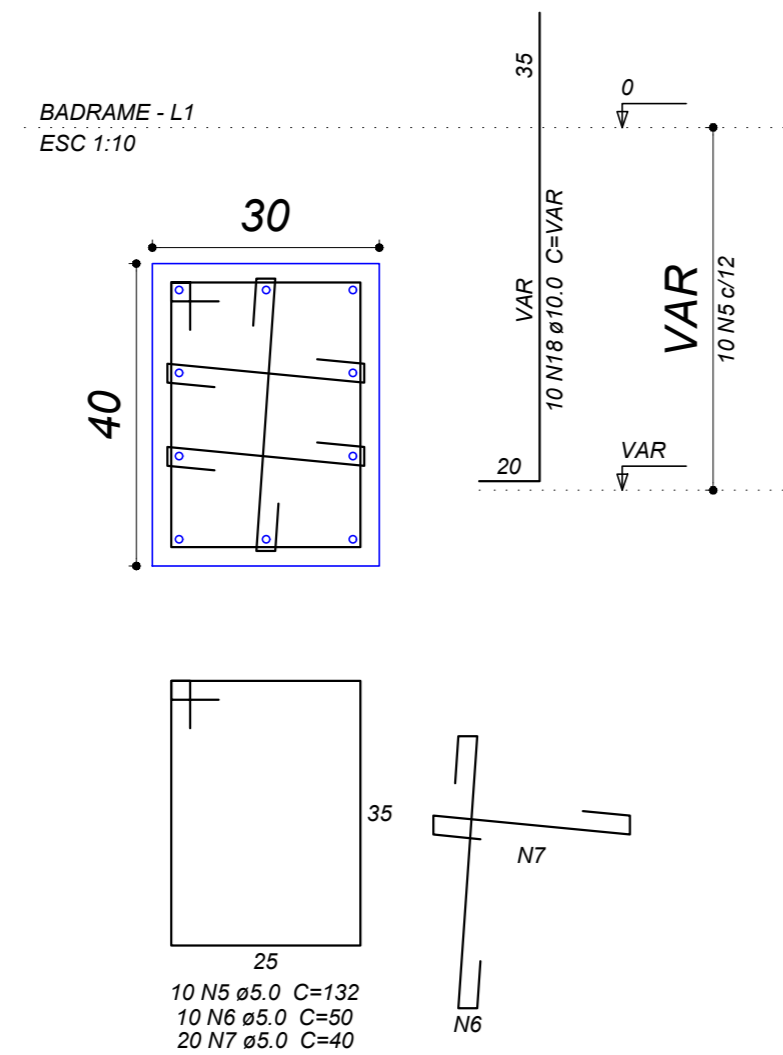

S40=S51
PLANTA
ESC 1:25

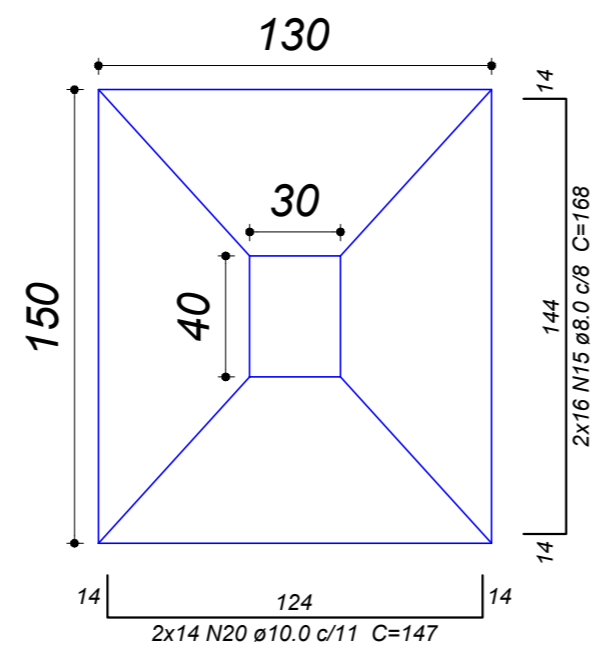

CORTE
ESC 1:25

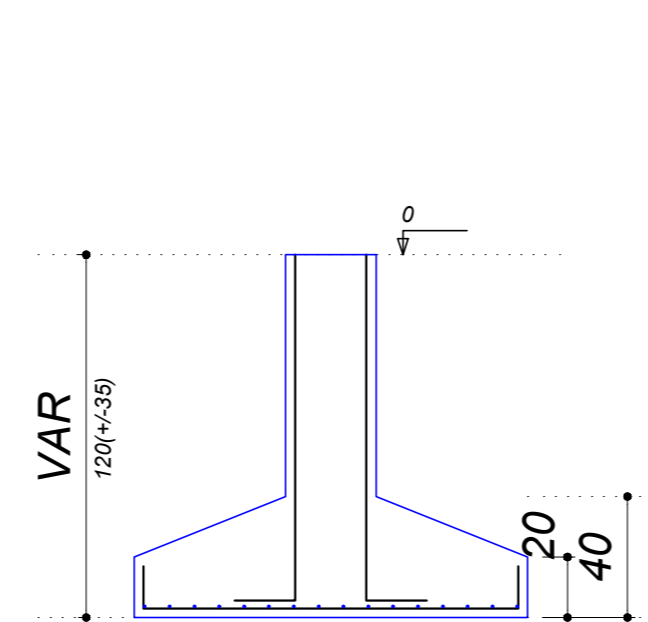

P61

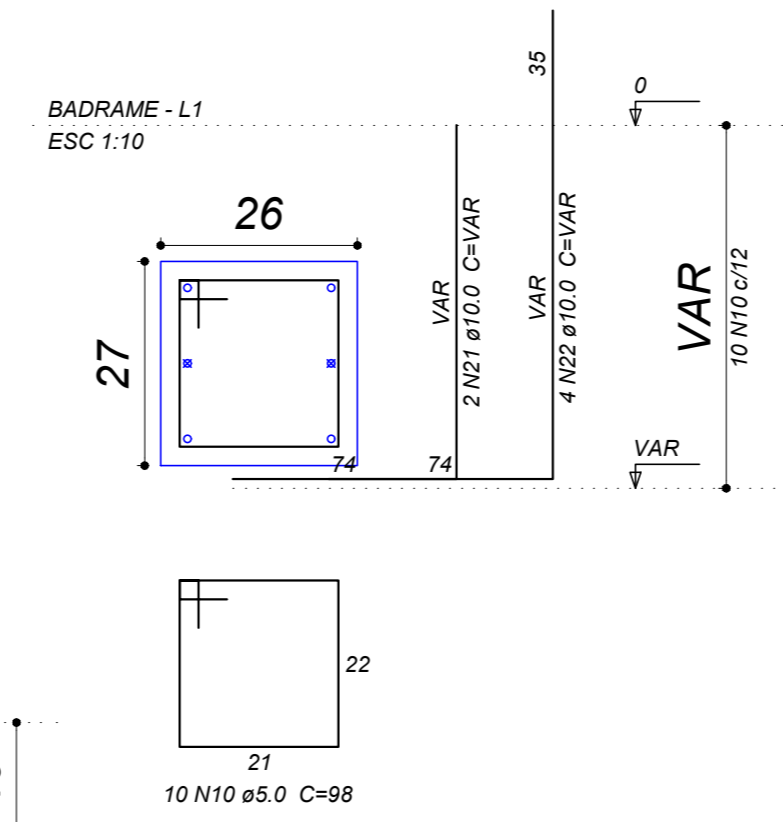

S61
PLANTA
ESC 1:25

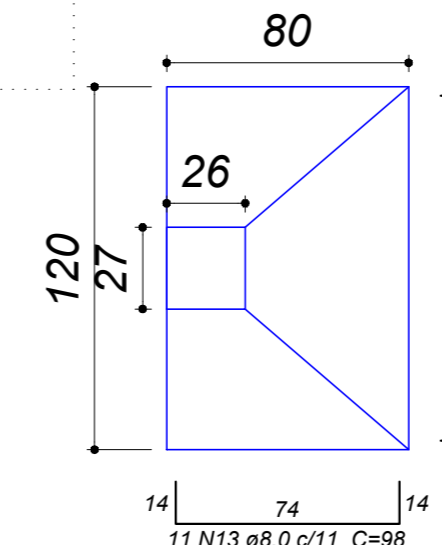

CORTE
ESC 1:25

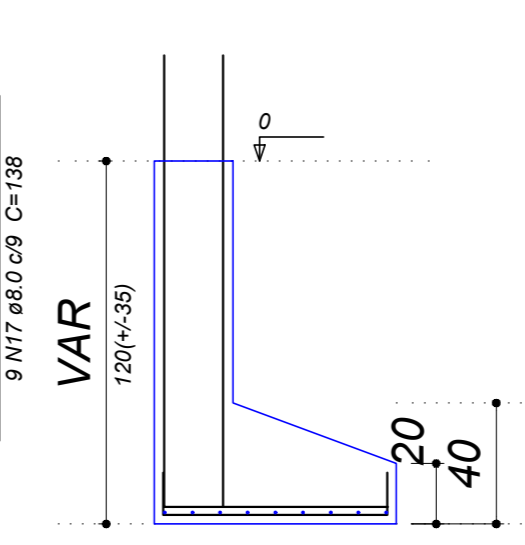

OBS.: TODAS AS UNIDADES DE MEDIDA DO PRESENTE PROJETO ESTÃO EM METROS.
CARIMBOS / APROVAÇÕES

É PROIBIDA A REPRODUÇÃO TOTAL OU PARCIAL DESTA OBRA, SEM A AUTORIZAÇÃO DA EMPRESA PROJETISTA.
LEI Nº 5194 DE 24/12/1966 (ART. 17 E 18) / LEI 9610 DE 19/02/98 (ART. 7 INCISO X)

EMPRESA CONTRATADA	RESPONSÁVEL TÉCNICO	PROPRIETÁRIOS
AZEVEDO PROJETOS E ACESSORIA CNPJ Nº: 31.219.623/0001-97	TIAGO PONATH ARQUITETO E URBANISTA CAU A121353-9	MUNICÍPIO DE ANCHIETA PROPRIETÁRIO CNPJ Nº: 83.024.687/0001-22

OBRA / ENDEREÇO
GINÁSIO DE ESPORTES
RUA OLÍMPICO DAL MAGRO S/N, CENTRO - MUNICÍPIO DE ANCHIETA/SC

PROPRIETÁRIO
MUNICÍPIO DE ANCHIETA

PROJETO
PROJETO ESTRUTURAL

AUTORA
TIAGO PONATH
ARQUITETO E URBANISTA
CAU A121353-9

DES. APROV. 428.3126-1733
ESCALA INDICADA
DATA OUT/2021

CONTEÚDO DA PRANCHA
CONTRA PISO ARMADO

REV	PROJETO	FASE	FOLHA	TOTAL
00	EXE	PE	33	45

AZEVEDO
projetos e acessoria